

Fabrication Materials: Stainless Steel 304L
Finish: Electro-polished

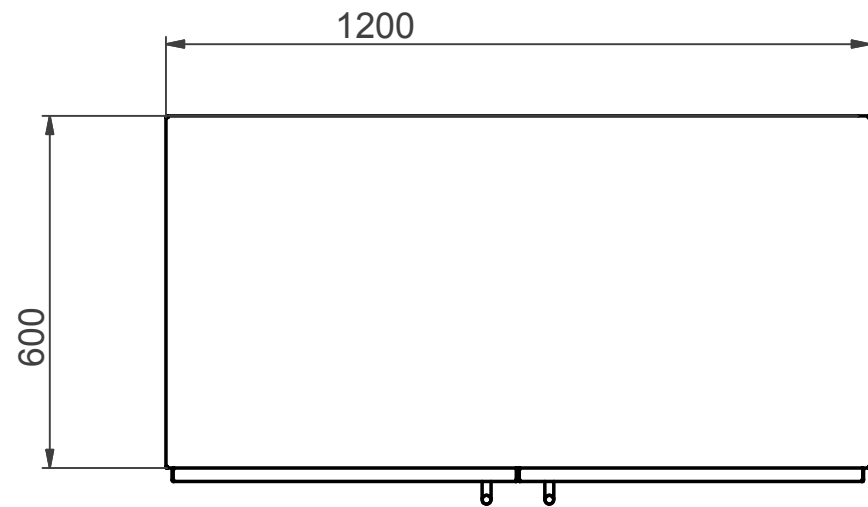
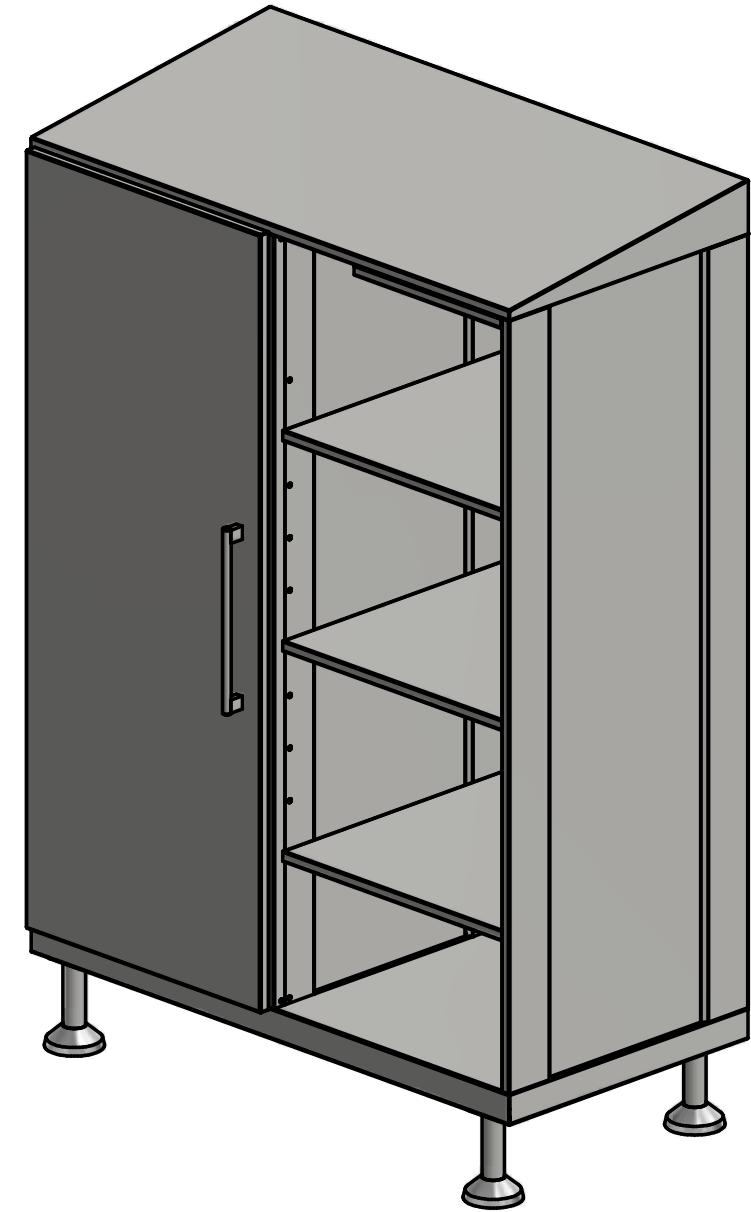
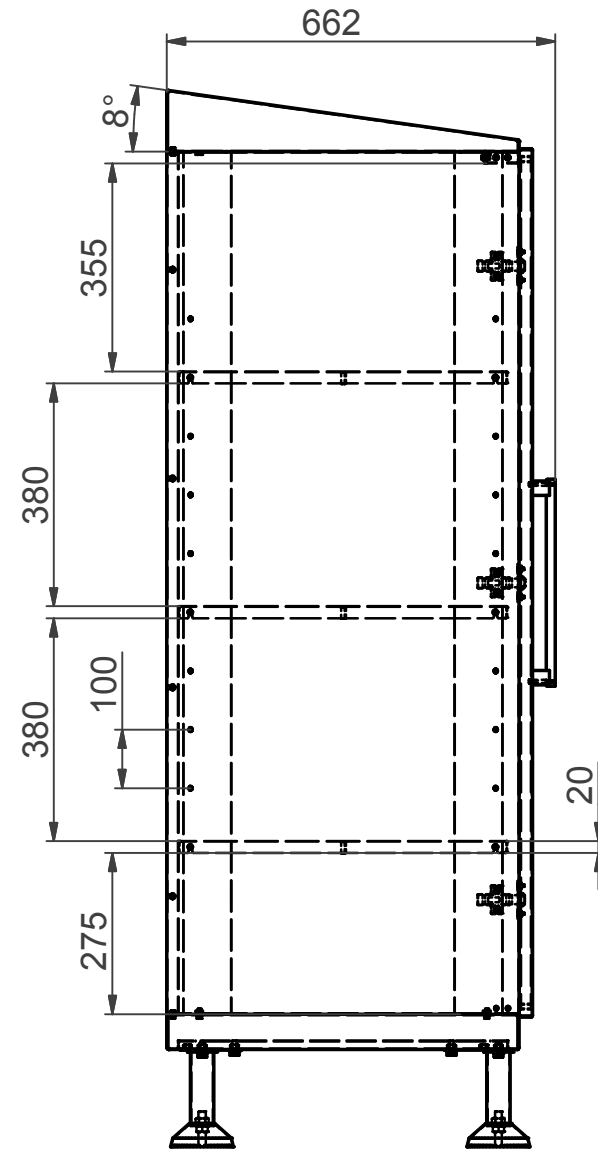
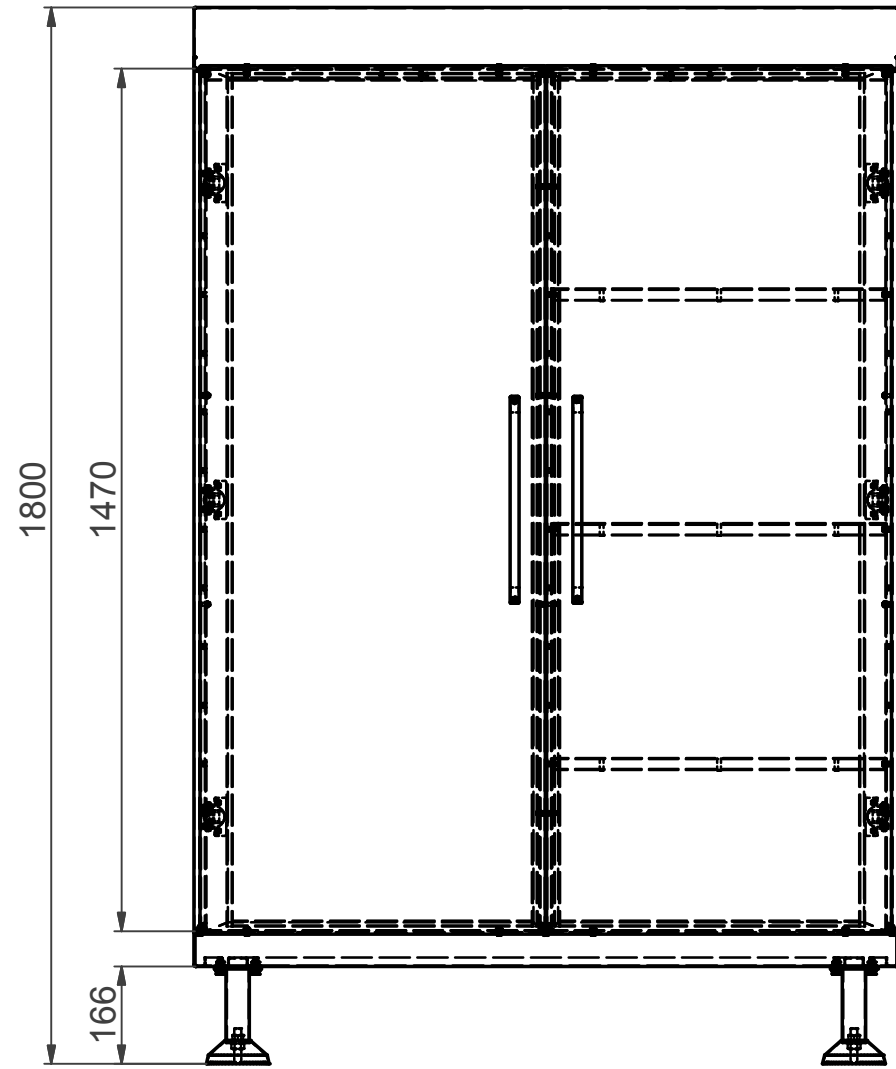

Estimation total weight 114 kg	VARIATION IN DIMENSIONS WITHOUT TOLERANCE IND. DIN 7168		PalbamClass EN HAROD IHUD	EUROPE PROJ
	BREAK EDGES 0.3x45	STATUS MEDIUM		REV A
ALL RIGHTS STRICTLY RESERVED USE. REPRODUCTION OR ISSUE TO THIRD PARTY IN ANY FORM WHATEVER IS NOT PERMITTED UNLESS AUTHORIZED IN WRITING BY THE PROPRIETOR PalbamClass IL-18960 EN-HAROD IHUD-ISRAEL.	INNER RADIUS	SURF. ROUGH. PER ISO 1302	Cleaners Cabinet	
	DESIG	DATE 27/09/2016	NAME Alexey	SCALE 1:12.5
	APPR		DWG. No.	A3
			PCJC1260-000	SHEET 1 / 1

CONTROLLED COPIES OF THIS DOCUMENT HAVE A RED ISSUE DATE STAMP, THESE COPIES WILL BE UPDATED BY PALBAM CLASS INFORMATION SYSTEM. ANY OTHER COPY IS NOT CONTROLLED AND THEREFORE NOT UPDATED. PLEASE CHECK WITH INFORMATION SYSTEM FOR VALIDITY OF DOCUMENT.