

Fabrication materials: Stainless Steel 304L with electro-polished finish & Aluminium anodized connectors

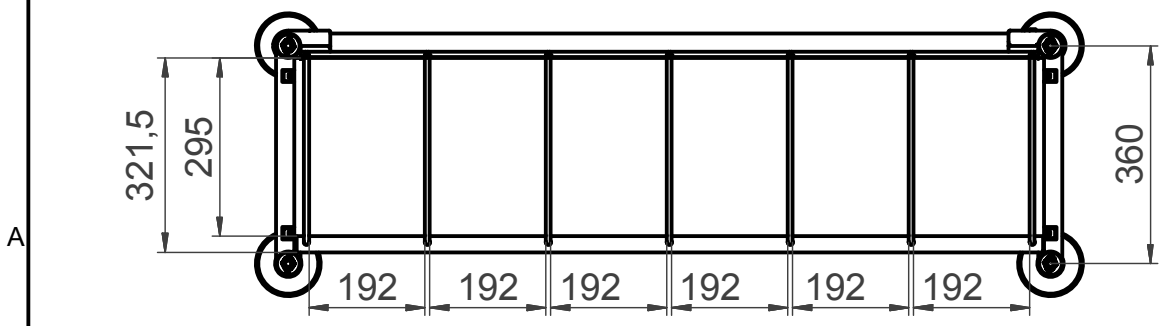
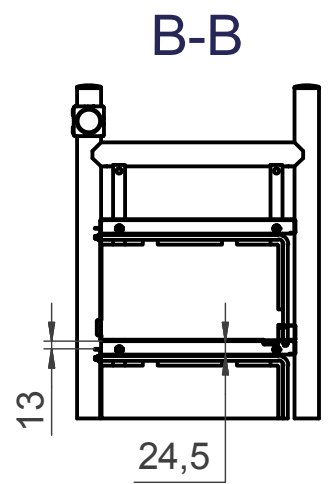
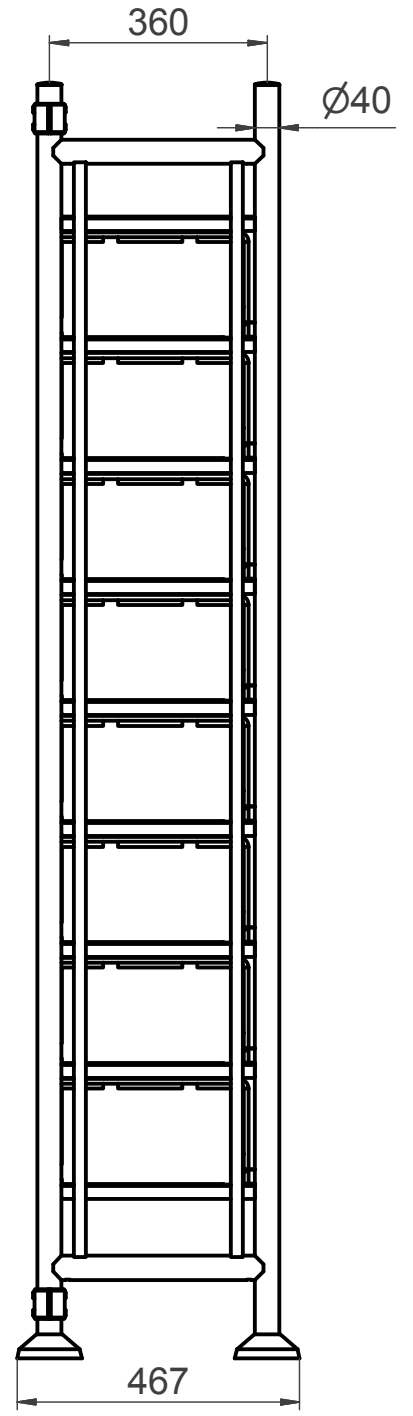
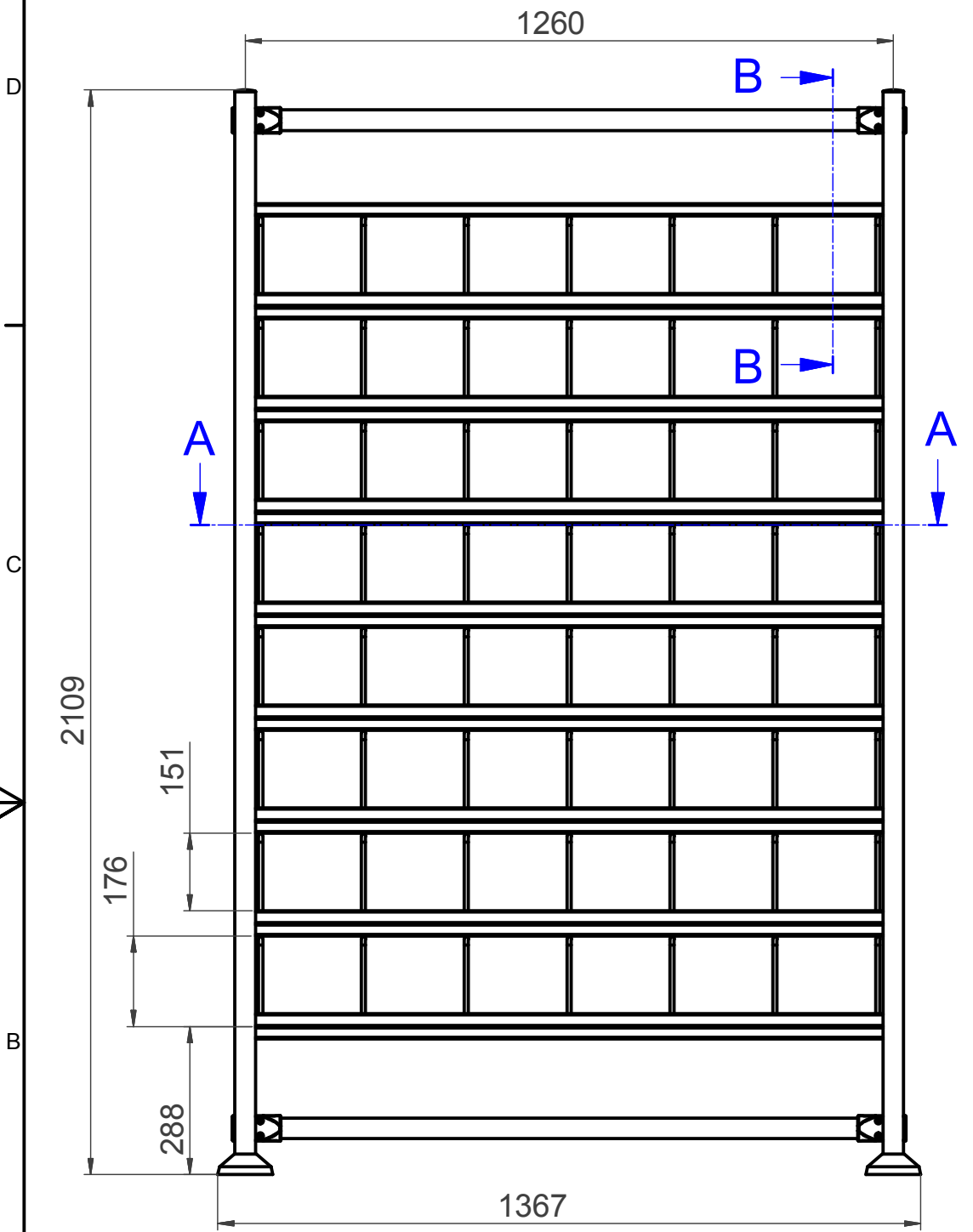

Estimation total weight 150 kg	VARIATION IN DIMENSIONS WITHOUT TOLERANCE IND. DIN 7168		PalbamClass EN HAROD IHUD	EUROPE PROJ 	
	BREAK EDGES 0.3x45	STATUS MEDIUM			REV A
ALL RIGHTS STRICTLY RESERVED USE, REPRODUCTION OR ISSUE TO THIRD PARTY IN ANY FORM WHATEVER IS NOT PERMITTED UNLESS AUTHORIZED IN WRITING BY THE PROPRIETOR PalbamClass IL-18960 EN-HAROD IHUD-ISRAEL.	INNER RADIUS	SURF. ROUGH. PER ISO 1302	Cubby Rack 48		
	DATE	NAME	SCALE	A3	
	DESG	02/12/2009	Alexey	DWG. No.	PCGC1302-000
	APPR			SHEET	1 / 1
CONTROLLED COPIES OF THIS DOCUMENT HAVE A RED ISSUE DATE STAMP, THESE COPIES WILL BE UPDATED BY PALBAM CLASS INFORMATION SYSTEM. ANY OTHER COPY IS NOT CONTROLLED AND THEREFORE NOT UPDATED. PLEASE CHECK WITH INFORMATION SYSTEM FOR VALIDITY OF DOCUMENT.					